

Extraction Arm Telescopic



The Nederman Telescopic arm is specially designed for working environments with fumes, vapours or non explosive dust, where the space is limited. Typical workplaces can be welding schools or for production in small welding booths. The applications can be welding, grinding, or other industrial processes where a small, easily positioned arm is required. The reach of the arm is between 0.9 and 1.6 m (3 and 5 ft.).



- The arm is flexible in all directions and simple to position and to extend
- The arm has a balanced telescopic action by an adjustable balance block
- The assembly is suspended by a swivel, which allows it to rotate 360 degrees
- The hood can be tilted in all directions

Pressure drop

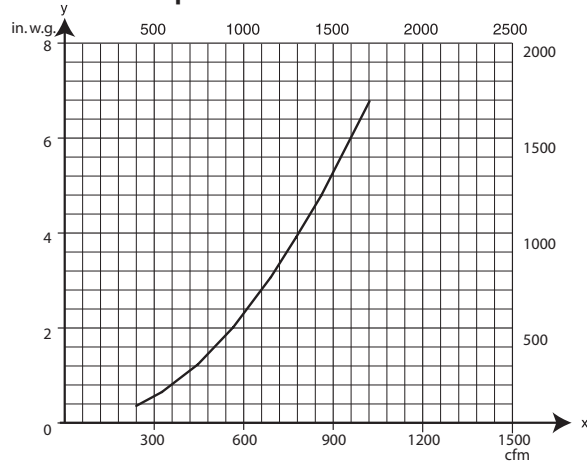

X: airflow m^3/h (cfm)
Y: static pressure Pa

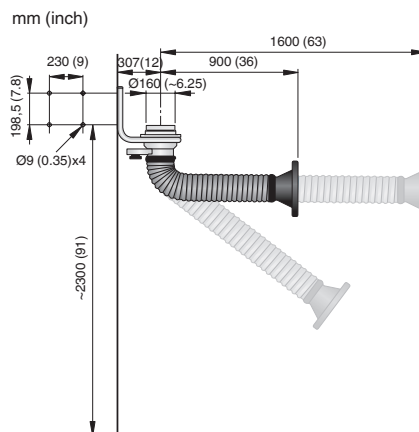

Description	Reach, m (ft.)	Airflow, m^3/h (cfm)	Connection Ø, mm (in)	Max. fume temperature, °C (°F)	Noise level at hood, dB(A)	Weight, kg (lb.)	Part no.
Telescopic arm with metal hood with damper	0.9-1.6 (3 - 5)	600-1000 (350-600)	160 (6 ¼)	70 (160)	76	12 (26)	10502731
Telescopic arm with metal hood without damper	0.9-1.6 (3 - 5)	600-1000 (350-600)	160 (6 ¼)	70 (160)	76	12 (26)	10502531
Telescopic arm with Original hood	0.9-1.6 (3 - 5)	600-1000 (350-600)	160 (6 ¼)	70 (160)	76	12 (26)	10502331

Product availability may differ by country