

# Vacuum Hose Reel Series 881 Ex

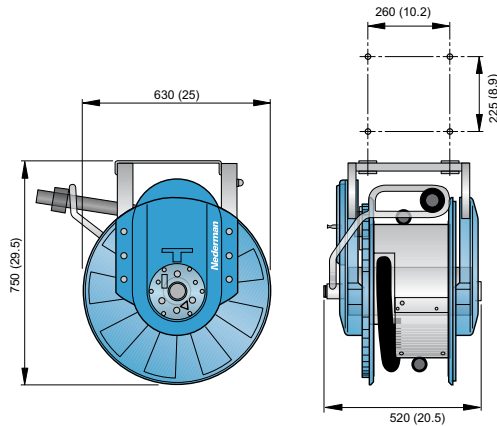

The vacuum hose reel facilitates the handling of long and heavy vacuum hoses, and provides tidy and safe storage when they are not in use. Keeps hoses out of the way of forklifts and mobile workshop equipment. Separate suspension brackets make installation of the reel simple and safe. All reels are delivered without connection hose. Approved for use in ATEX-zone 22 in accordance with ATEX 94/9/EC Equipment group II, Category 3D.

- Suitable for cleaning explosive dust
- With built-in automatic damper
- Integrated micro-switch



Max. suction, kPa (psi)	Hose dimensions, Int. Ø, mm (in)	Hose dimensions, Length, m	Hose type (see page 21)	Weight, kg	Reel with hose Part no.	Reel without hose Part no.
45 (7)	38 (1 1/2)	10	L	26-28	30805881	30805981
45 (7)	50 (2)	10	L	26-28	30806081	

Material recycling: 100% N.B. All reels are delivered without connection hose.

Pipe system Ø, mm	Part no.
63	30374390
100	30374389

## Installation kits

The kits include all necessary installation material for pipe connections Ø 63 mm (2½ in) or Ø 100 mm (4 in) (branch coupler, joint sleeves, connecting hose P63, brackets 300 mm (12 in), pilot cable, connection box, straps, hose clamps).