

Compact, direct machine-mountable mist collectors designed to collect, filter, and reclaim mist generated from machines using oil-based, synthetic, semi-synthetic, or water-soluble coolants.

- Efficient, compact design handles mist and smoke applications from 100 - 1000 cfm (170 - 1699 m³/h)
- Three stages of filtration for high filtration efficiency and optimum filter life
- Available with high performance in-cover or in-line prefilters for removal of swarf and large chips and in-cover impingers for applications with heavy concentrations of fine mist
- High collection efficiency of 98% on 1.0 µm increasing to 99.97% at 0.3 µm with optional fourth stage HEPA filter
- Direct-mount capability minimizes ductwork
- Recirculation of clean air eliminates the need for costly make-up air
- Provides a cleaner work environment for maximum productivity
- Helps support OSHA Clean Air Standards



E-500



E-300 with HEPA

OPERATIONAL EXPLANATION

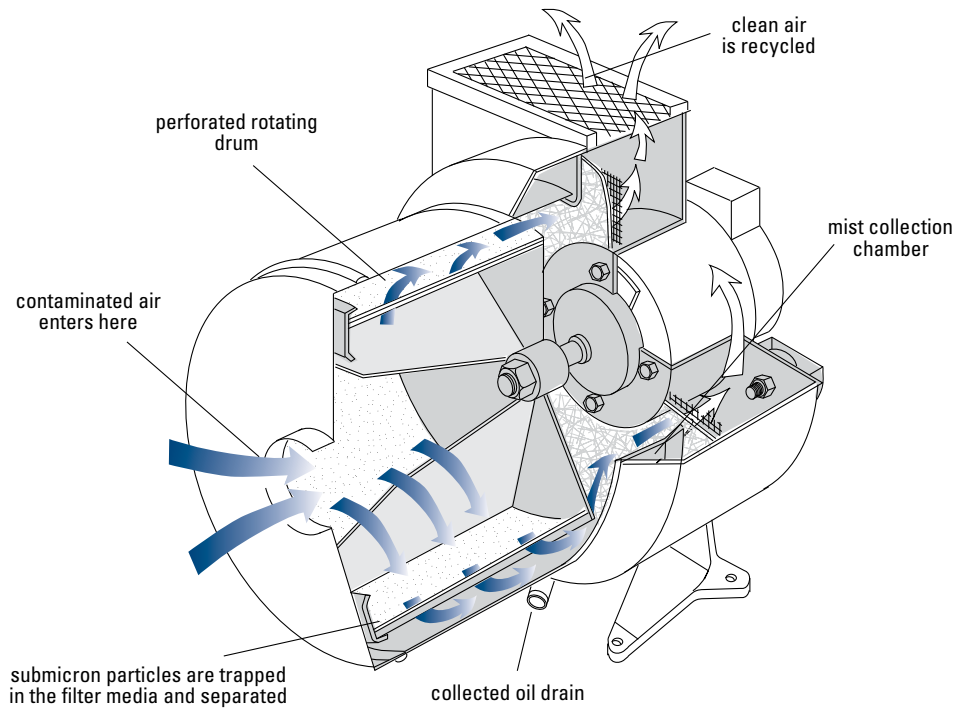

- Inexpensive, throwaway filter liners reduce maintenance costs
- Sturdy, compact, 16-gauge steel encasement is tough and solid for harsh industrial environments
- Optional HEPA and carbon filters are available on all models

PERFORMANCE SELECTIONS

Airflow at 60 Hz - 3450 RPM

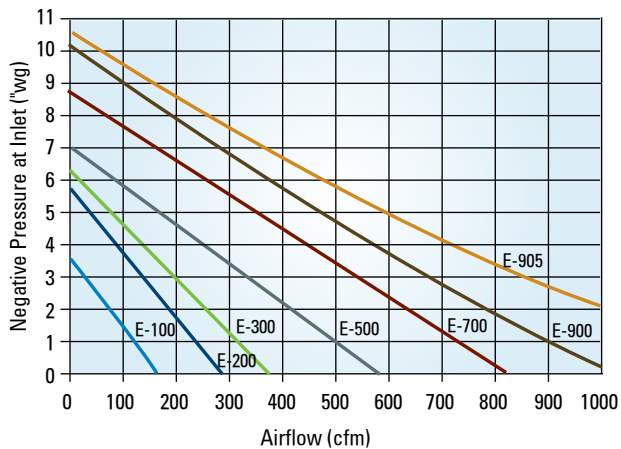

Particle Size vs. Collection Efficiency

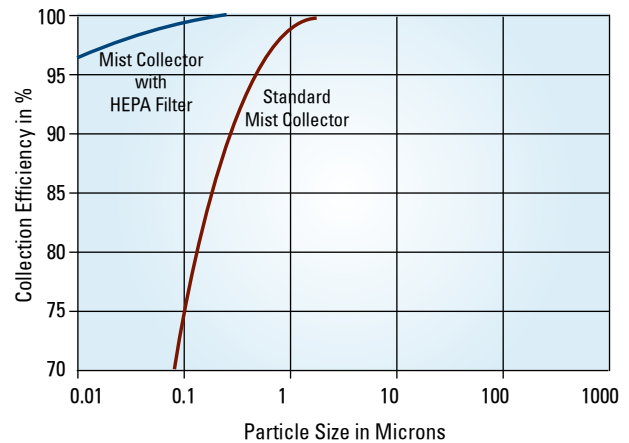

DIMENSIONS & SPECIFICATIONS

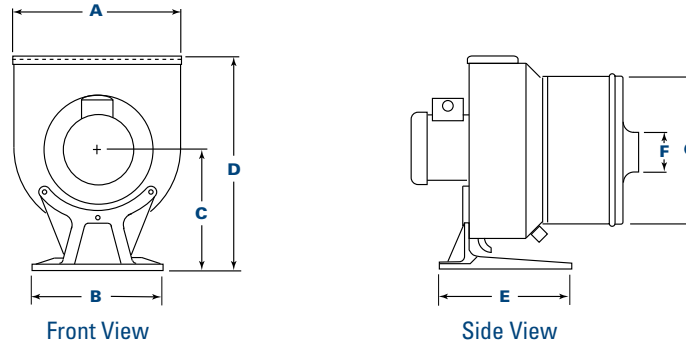

Model	Nominal Airflow*		Motor (hp)	Dimensions***												Sound Level dB(A)†	Shipping Weight			
	cfm @1TSP	m ³ /h @1TSP		A		B		C		D		E		F			G		lb	kg
	in	mm		in	mm	in	mm	in	mm	in	mm	in	mm	in	mm		in	mm		
E-100	100	170	0.5	14.9	378.5	11.5	292.1	11.5	292.1	19.4	492.8	11.5	292.1	3.9	99.1	14.5	368.3	70	125	56.7
E-200	200	340	0.5	14.9	378.5	11.5	292.1	11.5	292.1	19.4	492.8	11.5	292.1	3.9	99.1	14.5	368.3	70	125	56.7
E-300	300	510	1	17.1	434.3	11.5	292.1	12.3	312.4	21.4	543.6	11.5	292.1	3.9	99.1	14.5	368.3	72	145	65.8
E-500	500	849	1	17.1	434.3	11.5	292.1	12.3	312.4	21.4	543.6	11.5	292.1	5.9	149.9	14.5	368.3	72	145	65.8
EA-700	700	1189	3	20.8	528.3	11.5	292.1	12.3	312.4	23.2	589.3	11.5	292.1	5.9	149.9	18.3	464.8	74	190	86.2
EA-900	900	1529	3	20.8	528.3	11.5	292.1	12.3	312.4	23.2	589.3	11.5	292.1	5.9	149.9	18.3	464.8	74	190	86.2
EA-905	1000**	1699**	3	20.8	528.3	11.5	292.1	12.3	312.4	23.2	589.3	11.5	292.1	5.9	149.9	18.3	464.8	76	190	86.2

* Based on clean filters

** 1,000 cfm @ 2" (28.3 m³/m @ 50.8mm) External Static Pressure (ESP).

*** Dimensions do not include HEPA option.

† The actual measured sound level will vary, depending on background noise and room conditions.

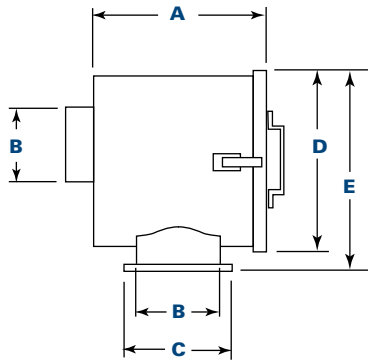

Horizontal Prefilter Trap

Model	Dimensions - Horizontal									
	A		B		C		D		E	
	in	mm	in	mm	in	mm	in	mm	in	mm
E-100	9.1	231.1	3.9	99.1	6.0	152.4	9.1	231.1	10.0	254.0
E-200	9.1	231.1	3.9	99.1	6.0	152.4	9.1	231.1	10.0	254.0
E-300	9.1	231.1	3.9	99.1	6.0	152.4	9.1	231.1	10.0	254.0
E-500	12.1	307.3	5.9	149.9	8.0	203.2	12.1	307.3	13.0	330.2
EA-700	12.1	307.3	5.9	149.9	8.0	203.2	12.1	307.3	13.0	330.2
EA-900	12.1	307.3	5.9	149.9	8.0	203.2	12.1	307.3	13.0	330.2
EA-905	12.1	307.3	5.9	149.9	8.0	203.2	12.1	307.3	13.0	330.2

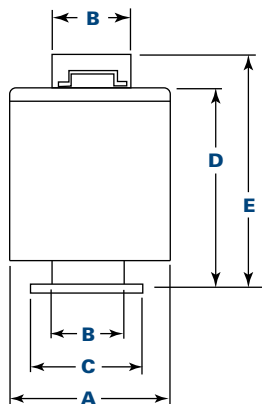

Vertical Prefilter Trap

Model	Dimensions - Vertical									
	A		B		C		D		E	
	in	mm	in	mm	in	mm	in	mm	in	mm
E-100	9.1	231.1	3.9	99.1	6.0	152.4	10.8	274.3	11.8	299.7
E-200	9.1	231.1	3.9	99.1	6.0	152.4	10.8	274.3	11.8	299.7
E-300	9.1	231.1	3.9	99.1	6.0	152.4	10.8	274.3	11.8	299.7
E-500	12.3	312.4	5.9	149.9	8.0	203.2	14.1	358.1	15.5	393.7
EA-700	12.3	312.4	5.9	149.9	8.0	203.2	14.1	358.1	15.5	393.7
EA-900	12.3	312.4	5.9	149.9	8.0	203.2	14.1	358.1	15.5	393.7
EA-905	12.3	312.4	5.9	149.9	8.0	203.2	12.1	358.1	13.0	393.7

STANDARD FEATURES & AVAILABLE OPTIONS

Collector Design	Std	Opt
Heavy-Gauge Steel Construction	X	
Three Filtration Stages	X	
TEFC Motor	X	
Drain Kit	X	
3-Phase, 50-60 Hz Motor	X	
1-Phase, 60 Hz Motor		X
Flexible Inlet Hose Kit		X
Pedestal– 6' x 6" (152.4 mm x 152.4 mm)		X
Explosion Proof Motor		X
Aluminum Drum Assembly		X
Vibrator Isolators		X
Inlet Adapter		X
Prefilter Trap		X
In-Cover Trap		X
In-Cover Impinger		X

Filters and Liners	Std	Opt
Throwaway Liner	X	
Primary Filter	X	
Secondary Filter	X	
Exhaust Grill Filter	X	
Sock Filter (In-Line Prefilter)		X
Carbon Filter		X
HEPA Filter (Fourth Stage)		X
Paint System		
Textured Multi-Coat Paint Finish with 2,000-Hour Salt Spray Performance	X	
Premium Duty Finish		X
Custom Colors, Materials, and Finishes		X
Warranty		
10-Year Warranty	X	

Significantly improve the performance of your collector with genuine Donaldson Torit replacement filters and parts. **Call Donaldson Torit today 800-365-1331.**



Tel 800-365-1331 (USA)
Tel 800-343-3639 (within Mexico)

donaldsontorit@donaldson.com
donaldsontorit.com

Donaldson Company, Inc.
Torit
P.O. Box 1299
Minneapolis, MN
55440-1299 U.S.A.

EXACTLY WHAT YOU NEED.™

Centrifugal Mist Collectors – Models E & EA (11/12)
© 2009 Donaldson Co., Inc. All Rights Reserved. All products, product specifications, and data (airflow, capacity, dimensions, or availability) are subject to change without notice, and may vary by region or country. Donaldson Torit is a registered trademark of Donaldson Company, Inc. Contains Donaldson proprietary technology.